

XIV. *On the Quantity of Carbon in carbonic Acid, and on the Nature of the Diamond.* By William Allen, Esq. F. L. S. and William Hasledine Pepys, Esq. Communicated by Humphry Davy, Esq. Sec. R. S. M. R. I. A.

Read June 18, 1807.

THE estimates of the quantity of real carbon in carbonic acid differing very widely, and the experiments of GUYTON DE MORVEAU upon the combustion of the diamond, detailed in the 31st volume of the *Annales de Chimie*, being liable to some objections from the manner in which the operations were conducted, we determined to institute a set of experiments, in order, if possible, to settle the question.

LAVOISIER, from the result of experiments apparently conducted with much accuracy, concluded that every hundred parts by weight of carbonic acid consisted of 28 carbon and 72 oxygene. This was in a great degree confirmed by the very valuable researches of SMITHSON TENNANT, Esq. on the nature of the diamond, an account of which is printed in the Transactions of this Society for the year 1797, and which were made previously to the experiments of GUYTON; but notwithstanding this, the result of GUYTON's experiment, which only allowed 17,88 per cent. of carbon to carbonic acid, has been adopted in all the systems of chemistry to the present time.

In researches of this nature, the results are much influenced by slight variations in the quality of the gas; but having had repeated experience of the accuracy of the eudiometer described

in No. XII. of this volume, we were enabled to proceed in this respect with great confidence.

Our object was, to consume certain known quantities of diamond and other carbonaceous substances in oxygene gas, and we at first determined to employ the sun's rays, by means of a powerful lens; but considering the uncertainty of a favourable opportunity in this country, and at the season in which our experiments were made, we resolved to employ the apparatus represented by the drawing.

Description of the Apparatus.

This consisted of two mercurial gasometers, fig. 1 and 2, each capable of containing from 70 to 80 cubic inches of gas. The internal cylinder CC is of cast iron, and solid, except the perforation through its middle; the external cylinder is also of cast iron; and the glass receiver slides up and down in the space between them, which is filled with mercury: not more than sixteen pounds are required for each, and the small bath B, fig. 1.

To the top of each receiver, a graduated scale or register H, is screwed, shewing the number of cubic inches of gas, measuring from the upper edge of the external iron cylinder. The level of the mercury is ascertained by a small glass gauge. The registers were graduated by throwing up one cubic inch of gas at a time.

The gasometers stand upon mahogany stools, perforated for a socket, to which, according to the nature of the experiment, a small receiver R, or the triple socket TS, or any other combination, may be united.

P represents the platina tube with its furnance; the ends

of the tube are mounted with female screws of brass, to one of which the accommodating screw socket AS was joined.

T is a double section of the platina tray which contained the substances to be heated. During their combustion, it was made to slide easily within the platina tube P. The accommodating socket and platina tray, are drawn considerably larger in proportion than the instrument.

By means of the triple socket and the cocks, the gas was made to pass freely over the substances in combustion, from one gasometer to the other; and by shutting off the communication with the platina tube, while that with the small receiver was open, any portion of gas in the gasometer, fig. 1. might be transferred into eudiometers or measures standing in the mercury bath M, for examination.

In order to discover whether the several sockets were airtight, after the apparatus was put together, the communication with the gasometer, fig. 1, was closed, and the other communications opened; the receiver of the gasometer, fig. 2, being raised, drew up a column of mercury in the small receiver R, equal to two inches: the communication with the gasometer was then closed, and the column was supported without alteration. This was always tried previous to, and after every experiment. As the joints would bear this degree of exhaustion, we were confident they would resist a much greater pressure than we had any occasion to employ. The glass tubes GG, which connected the platina tube with the gasometers, enabled us to observe any flash arising from the combustion of hydrogen which might be contained in the substances subjected to experiment. In order to avoid prolixity, we shall generally state the method which was invariably followed.

We soon found that oxygene gas, even when secured in bottles with ground glass stoppers, was not always to be depended upon, but was sensibly deteriorated by keeping; and therefore in all our experiments we made the gas within an hour or two of the time of using it, and always from the hyperoxygenised muriate of potash. Its degree of purity was constantly ascertained by the eudiometer before every experiment, and was generally determined in about 10 minutes. The solution employed was that recommended by Professor DAVY; namely, the solution of green sulphate of iron saturated with nitrous gas;* and whenever the diminution had arrived at its maximum, and the gas began to increase in volume, we substituted a simple solution of the green sulphate of iron for that saturated with nitrous gas, and always had the most satisfactory results: for the simple sulphate absorbs any nitrous gas which may have escaped from the saturated solution, and the residuum in this case enables us to ascertain exactly the quantity of oxygene contained in the gas.

We determined to make our first experiment with charcoal, and as MOROZZO and ROUPPE had ascertained the absorbing properties of this substance, and as our results must obviously be influenced by it, our attention was directed to this point, the following quantities of different kinds of wood, sawed into slips $\frac{3}{16}$ of an inch were weighed.

White Fir,	300 grains.
Lignum Vitæ,	800
Box - - -	400
Beech - - -	500
English Oak,	250
Mahogany -	200

* This solution absorbs oxygene much more rapidly in warm weather than in cold.

These slips were put into small crucibles, and completely covered with dry sand. Heat was very gradually applied at first, until the volatile parts were dissipated; they were then kept about 40 minutes in a white heat. On being collected and weighed, while still warm, the charcoal from each was as follows:

Fir,	-	-	54,5	grs. equal to	18,17	per cent.
Lignum Vitæ,	138	-	-		17,25	
Box	-	81	-	-	20,25	
Beech	-	75	-	-	15	
Oak	-	43,5	-	-	17,40	
Mahogany	31,5	-	-		15,75	

These being exposed to the air during one week, increased in weight thus:

Fir,	-	-	13	per cent.
Lignum Vitæ,	9,6			
Box	-	-	14	
Beech	-	-	16,3	
Oak	-	-	16,5	
Mahogany	18			

Certain quantities being *confined* in common air increased very little in weight, and all in the same proportion; we are therefore much inclined to think that *this* increase is owing to an absorption of water from the air; and we repeatedly found that the greatest increase of weight took place in the first hour or two after exposure, and arrived at its maximum in less than 24 hours, as the following experiment, selected from several others, will prove.

40 grains of charcoal from willow wood, which had been put into a bottle with a ground glass stopper *immediately* after they

were removed from the fire, were exposed in the scale of a delicate balance, in a room where the thermometer was 62° FAHRENHEIT, barometer 30,26.

	Grains.	Total Increase.	Time.
6 o'clock P. M.	40		
$\frac{1}{2}$ past	40,7 + ,7		
7 - - -	41,3 + ,6	= 1,3	1 hour.
$\frac{1}{2}$ past	41,6 + ,3	= 1,6	$1\frac{1}{2}$ hours.
8 - - -	41,8 + ,2	= 1,8	2 hours.

The pieces were now spread out on paper after every weighing, to expose them more completely.

$\frac{1}{2}$ past 8	42,5 + ,7	= 2,5	$2\frac{1}{2}$ hours.
9 - - -	42,8 + ,3	= 2,8	3 hours.
$\frac{1}{2}$ past	43,1 + ,3	= 3,1	$3\frac{1}{2}$ hours.
10 - - -	43,3 + ,2	= 3,3	4 hours.
$\frac{1}{2}$ past	43,4 + ,1	= 3,4	$4\frac{1}{2}$ hours.

Here it was left all night.

10 A. M.	45 + 1,6	= 5	16 hours.
4 P. M.	45		
6 - - -	44,5 - ,5	= 4,5	24 hours.
9 - - -	44,4 - ,1	= 4,4	27 hours.

Next day.

$\frac{1}{2}$ past 8 A. M.	44,9 + ,5	= 4,9	$38\frac{1}{2}$ hours.
$\frac{1}{2}$ past 1 P. M.	44,7 - ,2	= 4,7	$43\frac{1}{2}$ hours.
10 - - -	44,5 - ,2	= 4,5	52 hours.

Hence charcoal seems to act as an hygrometer: its greatest increase was 5 grains on 40, or $12\frac{1}{2}$ per cent. And in order to ascertain to what the increase of weight was owing, we put 27,25 grains of charcoal, which had been thus exposed, into a small bottle and tube connected with a receiver standing in

the mercury bath, the whole of the vessels being also filled with mercury in order to exclude common air. Heat applied by an ARGAND'S lamp produced gas equal to about *half the bulk of the charcoal*; but as soon as the temperature of the mercury rose to 214° FAHRENHEIT, elastic fluid streamed from every piece of charcoal, which *quickly condensed*, and $1\frac{1}{4}$ inch of the tube was occupied with water. This proved that our suspicion of the increase of weight being principally attributable to water, was well founded.

The result of these, and other experiments, plainly pointed out the precautions which were necessary in order to obtain an accurate result with charcoal; for if we had weighed 4 grains of the charcoal a few hours after it was made, we should only in fact have had 3,5 grains of real charcoal, and our calculations would have been erroneous. To avoid this source of error, we subjected our charcoal to a red heat *immediately* before using it, and also weighed it as speedily as possible; in fact, while it was still warm. It may be proper to state, that our weights were such as we could thoroughly depend upon.

The volume of gas being so much influenced by temperature and pressure, these were noted during every experiment; and thermometer 60° FAHRENHEIT, barmometer 30° , were assumed as the standard. GAY LUSSAC remarks, that from 32° to 212° FAHRENHEIT, dry air expands 0,00208, or $\frac{1}{480}$ part of its bulk for every degree of the thermometer. DALTON makes it 0,000207, or $\frac{1}{483}$ part; we therefore divided the whole quantity of gas by 480, and multiplied the quotient by the degrees of difference under 60° .

It being of great consequence in these experiments to know

the *exact* weight of a given quantity of oxygene and carbonic acid gases, we resolved to examine for ourselves, whether the statements already given were quite correct, and accordingly made carbonic acid over mercury from Carrara marble and diluted sulphuric acid, which being tried with lime water in PEPYS'S eudiometer, was all absorbed in 3 minutes except 1 part in 100. We used two charges of lime water, though one would have been sufficient.

A glass globe being exhausted by an excellent air pump, was exactly balanced on a beam sensible to a minute portion of a grain; then being screwed upon one of the glass receivers of the mercurial gasometer previously filled with carbonic acid gas, 21 cubic inches entered. The globe was now increased in weight by 10,2 grains. In order to be certain we repeated the experiment, with exactly the same results. The 21 cubic inches were to be brought to the mean temperature and pressure, as the thermometer stood at 44° FAHRENHEIT, the barometer 29,86.

21	480) 21,00 (0,043	60°
,68 add for temp.	16	44
21,68	0,688 add for temp.	16 diff.

Correction for Pressure.

$$30 : 29,86 :: 21,68 : 21,58$$

The volume therefore at mean temperature and pressure would have been 21,58 cubic inches.

$$21,58 : 10,2 :: 100 : 47,26$$

Consequently 100 cubic inches of carbonic acid gas at mean temperature and pressure weigh 47,26 grains.

We next tried oxygene gas from the hyperoxygenised muriate of potash made over mercury, and which by the eudiometer left only a residuum of 2 parts in 100. The glass globe exhausted as before, and weighed, was screwed on to the glass receiver of the mercurial gasometer containing oxygene, and 21 cubic inches entered, by which it increased in weight 7,3 grains. This experiment was repeated with exactly the same result. The thermometer and barometer remaining the same, we take the volume as before corrected.

21,58 cubic inches.

$$21,58 : 7,3 :: 100 : 33,82$$

Then 100 cubic inches of oxygene gas at mean temperature and pressure weigh 33,82 grains. After these experiments, we examined DAVY'S researches on nitrous oxyde, and had the satisfaction to find that his estimate, both of carbonic acid and oxygene gases, agreed almost exactly with ours.

The next point was to ascertain whether lime water would take the whole of the carbonic acid gas from a mixture with oxygene, or common air; we therefore mixed a known quantity of carbonic acid gas with a certain quantity of common air, and on trying it with our eudiometer and lime water, the *whole* of the carbonic acid gas was in a short time absorbed. We also found, that though the solution of green sulphate saturated with nitrous gas would not take up the whole of the carbonic acid gas, yet the simple green sulphate, merely by its water of solution, absorbed it very readily.

It may be proper to notice here, that though we repeatedly tried the oxygene procured from hyperoxygenised muriate of potash by the eudiometer and lime water, it never gave the least trace of carbonic acid.

Experiment with Charcoal from Box-wood.

The thermometer being at 42° FAHRENHEIT, barometer at 30,2, we kept some box-wood charcoal red hot for a considerable time under sand, and weighed 4 grains as expeditiously as possible ; this being put into the platina tray, was pushed to the middle of the platina tube ; the oxygene (made from hyperoxygenised muriate of potash over mercury) was contained in gasometer No. 1 ; No. 2 was empty. Every thing being adjusted and found perfectly air-tight, the communication with the small receiver R was closed, and the common air contained in the tubes and sockets, amounting only to 2,84 cubic inches, was driven out by a pressure of oxygene from gasometer No. 1 : when several cubic inches had passed into gasometer No. 2, the gas was let out by opening the cock at the top of its glass receiver, and pressing it down ; the cock being then closed, the gasometer No. 2, was completely empty, and the whole of the gas from No. 1 was driven through the tubes into No. 2, and back again. The common air having been previously withdrawn from the small receiver R, we tried the purity of our oxygene by the eudiometer in the manner before described, and found a residuum of 3 parts in 100 : we then disengaged as much gas as reduced the quantity to 47 cubic inches by the register or scale ; to this must be added the contents of the tubes and sockets 2,84 cubic inches, making the total quantity of oxygene employed 49,84 cubic inches.

Correction for Temperature.

49,84	480)49,84(0,103	60°	
1,85 for temp.	18	42	
51,69	1,854 add for temp.	18	diff.

Correction for Pressure.

$$30 : 30,2 : : 51,69 : 52,03.$$

The volume, therefore, at mean pressure and temperature, would have been 52,03 cubic inches.

We now lighted a fire in the small black lead furnace under the platina tube, and as soon as it became red hot, opened the cocks and passed the gas from No. 1 to No. 2, when the charcoal entered into vivid combustion, and heated the platina tube white hot. The operation was repeated many times during 6 or 7 minutes, by pressing alternately upon the glasses of the gasometers. Not the least flash of light was observable in the glass connecting tubes G G, nor the smallest appearance of moisture. The furnace being removed, the tube was now cooled by the application of wet cloths; and when all was reduced to the temperature of the room, we pressed upon the glass of gasometer No. 2, so as to force all the gas into No. 1. The cock below being closed, we tried the tubes, &c. and found them perfectly air-tight. We next unscrewed the tube and took out the platina tray; but it only contained a light white ash, somewhat resembling the shape of the pieces of charcoal, and weighing only ,02 of a grain. On observing the register of No. 1, it indicated exactly the quantity of gas that we began with, so that although 3,98 grains of charcoal had been dissolved, the volume of gas was *unaltered* by it; a circumstance which had been remarked before by LAVOISIER. The small receiver R was now nearly full of mercury; the communication with the gasometer being opened, the large glass receiver was gently pressed upon, until several cubic inches were forced through the receiver R, and tube K, in order to clear the latter of common air. This being done, on trying our gas with the eudiometer and lime

water, 56 parts were absorbed out of 100. These of course were carbonic acid gas; the test for oxygene absorbed 41, and a residuum of 3 was left, which was exactly what we began with. This is a striking proof that nothing but carbonic acid was produced in the experiment.

$$100 : 56 :: 52,03 : 29,13.$$

Then 29,13 cubic inches of carbonic acid gas were produced.

$$100 : 47,26 :: 29,13 : 13,76.$$

These 29,13 cubic inches of carbonic acid gas would therefore weigh 13,76 grains.

The charcoal weighed	4	grains.
The residual white ash	0,02	
Charcoal consumed	3,98	grains.

Then if 13,76 grains, the weight of the carbonic acid produced, contain 3,98 of charcoal, 100 grains must contain 28,92.

$$13,76 : 3,98 :: 100 : 28,92.$$

Then, according to this experiment, 100 grains of carbonic acid gas contain 28,92 charcoal.

The gas before the experiment consisted of

Oxygene	50,47	cubic inches.
Azote	1,56	
	52,03	

After the Experiment,

Carbonic acid	29,13	cubic inches.
Oxygene	21,34	
Azote	1,56	
	52,03	

Now as the volume of gas was unaltered, it will be fair to consider the quantity of oxygene gas consumed as equal to the carbonic acid produced, or 29,13 cubic inches.

Then, if 100 cubic inches of oxygene weigh 33,82 grains, 29,13 cubic inches will weigh 9,85 grains.

$$100 : 33,82 :: 29,13 : 9,85.$$

The weight of oxygene consumed was therefore 9,85 grains.

Charcoal consumed	-	-	-	3,98
				<hr style="width: 100%;"/>
Carbonic acid from this statement				13,83 grains.
Ditto by calculations on carb. acid gas				13,76
				<hr style="width: 100%;"/>
				,07
				<hr style="width: 100%;"/>

$$13,83 : 3,98 :: 100 : 28,77.$$

Thus, calculating by the oxygene consumed, 100 grains of carbonic acid gas contain 28,77 charcoal.

First Experiment on Diamond.

Thermometer 56° FAHRENHEIT, barometer 30,20.

Our oxygene was made as in the former experiment: it contained no carbonic acid; and on being tried with the impregnated green sulphate, left a residuum of 3 parts in 100.

Having selected nine of the clearest and most transparent Brazil diamonds, we found they weighed 3,95 grains. These were ranged in the platina tray, which was placed in the tube, and the whole apparatus, adjusted as before, was perfectly airtight. The quantity of oxygene was 49,84 cubic inches, as in the last experiment. The same precautions were used to secure accuracy in the results as in the former experiment; and it would only be an unnecessary intrusion on the time of the Society to repeat them. The platina tube was heated red-hot,

and kept so for ten minutes; during this time the gas was repeatedly passed from one gasometer to the other; the tube did not become white hot, as in the experiment with charcoal, because in this case the combustion went on more slowly. When every thing was cooled to the temperature of the room, the gas was all passed into No. 1, by pressing down the receiver of No. 2, and the volume was precisely the same as when we began the experiment. On drawing out the tray, we observed that some of the diamonds were reduced to a minute speck, and all of them resembled opake white enamel: there was no discoloration in the tray, nor any residual ash whatever; the unconsumed parts weighed 1,46 grains; the original weight

was 3,95
1,46

consequently 2,49 grains were consumed.

We could not perceive any dullness on the surface of the mercury in the gasometers, or any appearance of moisture.

On introducing lime water to 100 parts of the gas in the eudiometer, a dense white precipitate was formed, and 36 parts absorbed; the test for oxygene absorbed 60, and a residuum of 4 was left.

Correction for Temperature.

60°	480)49,84(0,103	49,84	
56	4	,41	add for temp.
4 difference.	,412	50,25	

Correction for Pressure.

$$30 : 30,20 :: 50,25 : 50,58.$$

The quantity of oxygene at the mean was 50,58 cubic inches.

$$100 : 36 :: 50,58 : 18,20 \text{ cubic inches.}$$

The quantity of carbonic acid gas produced was 18,20 cubic inches.

$$100 : 47,26 :: 18,20 :: 8,60 \text{ grains.}$$

$$8,60 : 2,49 :: 100 : 28,95.$$

Then 100 grains of carbonic acid gas contain 28,95 of diamond.

Calculation by Oxygene.

$$100 : 33,82 :: 18,20 : 6,15 \text{ grains of oxygene consumed}$$

$$2,49 \text{ grains of diamond.}$$

$$\begin{array}{r} 8,64 \\ \text{Calculation by carbonic acid } 8,60 \\ \hline \end{array}$$

$$\begin{array}{r} .04 \text{ difference.} \\ \hline \end{array}$$

$$8,64 : 2,49 :: 100 : 28,81.$$

Thus if we calculate upon the oxygene consumed, 100 grains of carbonic acid gas contain 28,81 of diamond.

Second Experiment on Diamond.

Thermometer 48° FAHRENHEIT, barometer 30,08. Oxygene gas made as usual, left a residuum of 3 parts in 100.

Eleven small diamonds, weighing 4,01 grains, were put into the tray. We began with 49,84 cubic inches of oxygene; and every thing being properly adjusted, kept the platina tube red-hot for a quarter of an hour, and during this time the gas was passed from one gasometer to the other, as in the former experiments. When the tubes, &c. were cooled down to the temperature of the room, all the gas was transferred to gasometer No. 1. and the volume was exactly the same as before the experiment. On examining the tray, all the diamonds were entirely consumed and not a vestige left.

Lime water absorbed 57.5 parts from 100.

The test for oxygene 39.5

Residuum	-	3
		<hr style="width: 50%; margin: 0 auto;"/>
		100

Correction for Temperature.

60°	0,103	49,84
48	12	1,23
	<hr style="width: 50%; margin: 0 auto;"/>	<hr style="width: 50%; margin: 0 auto;"/>
12 diff.	1,236 add for temp.	51,07
	<hr style="width: 50%; margin: 0 auto;"/>	<hr style="width: 50%; margin: 0 auto;"/>

Correction for Pressure.

$30 : 30,08 :: 51,07 : 51,20.$

The volume of gas at the mean was therefore 51,20 cubic inches.

$100 : 57,50 :: 51,20 : 29,44.$

Then 29,44 cubic inches of carbonic acid gas were produced.

$100 : 47,26 :: 29,44 : 13,91,$

$13,91 : 4,01 :: 100 : 28,82.$

Then, according to this experiment, 100 grains of carbonic acid contain 28,82 diamond.

Calculation by Oxygene.

$100 : 33,82 :: 29,44 : 9,95$ grains of oxygene consumed
4,01 of diamond.

13,96

Calculation by carbonic acid 13,91

,05 difference.

$13,96 : 4,01 :: 100 : 28,72.$

Then, calculating by the weight of oxygene employed, 100 grains of carbonic acid contain 28,72 diamond.

The precipitate in lime water from the gas produced in the combustion of diamond, appeared to us denser than that from the combustion of charcoal.

In order to see how far the weight of the precipitate of carbonate of lime would agree with the results of the foregoing experiments, we drew off 20,5 cubic inches of the gas which had been thus altered by the combustion of diamond in the last experiment by the register H, and received it in bottles over mercury; then admitting lime water, we obtained a copious precipitate of carbonate of lime, which being dried at the temperature of 212° FAHRENHEIT, weighed 12 grains.

But as the 20,5 cubic inches require the same corrections to bring them to the mean temperature and pressure; we say, as the actual volume of all the gas is to its correction, so is the quantity drawn off to that which it would have been at the mean :

49,84 : 51,20 :: 20,50 : 21,06, the volume after the corrections were made.

Then, to find how much carbonic acid was contained in these 21,06 cubic inches, we state it thus : As the total quantity of gas after the experiment is to the total weight of carbonic acid gas found by calculation, so is the quantity of gas experimented upon to the weight of carbonic acid gas which it ought to have contained,

$$51,20 : 13,91 :: 21,06 : 5,72 \text{ grains.}$$

Every 100 grains of precipitated carbonate of lime contain 44 grains of carbonic acid; 12 grains were procured in our experiment.

$$100 : 44 :: 12 : 5,28$$

Therefore the carbonic acid contained in our precipitate of 12 grains weighed 5,28; by calculation it should have weighed

5,72; this is as near as we had a right to expect from the difficulty of collecting the precipitate.

Stone Coal.

Upon the suggestion of our mutual friend Professor DAVY, we next examined the results of the combustion of stone coal and plumbago; thermometer 57° FAHRENHEIT, barometer 29,65.

The stone coal from Wales, employed by maltsters, is well known to contain little or no maltha or mineral pitch, and to burn without flame.

A portion of this coal was placed under sand in a crucible, and exposed to a strong heat for one hour; 4 grains of it thus prepared were put into the tray: our oxygene left a residuum of 5 parts in 100, and we began with 49,84 cubic inches as usual. The tray being placed in the platina tube was heated to redness for about 10 minutes. When the gas was first passed, we thought we saw a flash in the glass tubes. On suffering the whole to cool the quantity of gas still remained the same, and the tray being drawn out contained only ,5 of a grain unconsumed. From the gas thus charged with 3,5 grains of coal,

Lime water absorbed	53	parts from 100.
The tests for oxygene	39	
Residuum	-	8 or an increase of 3.
	100	

Correction for Temperature.

60°	0,103	49,84
57	3	30
3 diff.	0,309	50,14
	add for temp.	

Correction for Pressure,

$$30 : 29,65 :: 50,14 : 49,55.$$

The quantity of oxygene at the mean was therefore 49,55 cubic inches.

$$100 : 53 :: 49,55 : 26,26.$$

Consequently 26,26 cubic inches of carbonic acid gas were produced.

$$100 : 47,26 :: 26,26 : 12,41 \text{ grains.}$$

$$12,41 : 3,50 :: 100 : 28,20.$$

Then, according to this experiment, 100 grains of carbonic acid gas contain 28,20 of coal.

Calculation by Oxygene.

$$100 : 33,82 :: 26,26 : 8,88 \text{ grains of oxygene consumed.}$$

$$3,50 \text{ coal}$$

$$12,38$$

Calculation by carbonic acid	12,41
------------------------------	-------

by oxygene	12,38
------------	-------

difference	,03
------------	-----

Here, contrary to what happened in other experiments, the calculation by carbonic acid rather exceeds that by oxygene:

$$12,38 : 3,50 :: 100 : 28,27.$$

Calculating therefore by oxygene, 100 grains of carbonic acid contain 28,27 of coal.

Experiment with Plumbago.

Thermometer 44° FAHRENHEIT, barometer 29,94.

4 grains of plumbago, from a very fine specimen belonging to Dr. BABINGTON, were put into the tray. Our oxygene left

a residuum of 2 parts in 100, and we began with 49,84 cubic inches. The tray, with its contents, being placed in the platina tube, was heated to redness for a quarter of an hour, and the gas made to pass over it several times. When all was cool, the original quantity was neither increased nor diminished, and on withdrawing the tray we found only 2 of a grain of oxide of iron; so that this specimen of plumbago contains only 5 per cent. oxide of iron.

The gas being now examined,

Lime water absorbed 55 parts from 100

The tests for oxygene 42

Residuum - - 3 or an increase of 1 per cent.

100

Correction for Temperature.

60°	0,103	49,84
44	16	1,64
<hr/>	<hr/>	<hr/>
16 diff.	1,648 add for temp.	51,48
<hr/>	<hr/>	<hr/>

Correction for Pressure.

$$30 : 29,94 :: 51,48 : 51,37.$$

The quantity of oxygene at the mean would be 51,37 cubic inches.

$$100 : 55 :: 51,37 : 28,25.$$

Therefore 28,25 cubic inches of carbonic acid gas were produced.

$$100 : 47,26 :: 28,25 : 13,35 \text{ grains.}$$

$$13,35 : 3,8 :: 100 : 28,46.$$

Then, according to this experiment, 100 grains of carbonic acid contain 28,46 of the carbonaceous part of the plumbago.

Calculation by Oxygene.

100 : 33,82 :: 28,25 : 9,55 grains of oxygene
consumed 3,80 plumbago.

Calculation by carbonic acid $\frac{13,35}{13,35}$

First Experiment on animal Charcoal.

Thermometer 60° FAHRENHEIT, barometer 30,23.

Muscular fibre distilled in a coated glass retort left a black shining coal, 4 grains of which were put into the tray. Our oxygene left a residuum of 2 parts in 100. The tray and its contents being placed in the platina tube, was heated to redness for 8 minutes. The first time the gas was passed, a lam-bent flame filled the whole length of the glass tube, and the gas became turbid or milky. It was passed frequently through the heated tube, but we observed no repetition of the flashes. Hence we conjecture that if the diamond had contained hydrogene, we should probably have had a similar appearance. After the experiment all the apparatus was, as usual, perfectly tight, and the volume of gas unaltered. On examining the platina tray a minute portion of charcoal remained, and a quantity of saline matter adhered to it so firmly, that it became difficult to ascertain the quantity of carbon consumed, and we forbore to make the calculation; we however examined the gas.

Lime water absorbed 40 parts from 100

The tests for oxygene 54

Residuum - - 6 or an increase of 4 per cent.

$\frac{100}{100}$

Second Experiment on animal Charcoal.

Thermometer 59° FAHRENHEIT, barometer 29.45.

Some of the animal charcoal of last experiment was heated to redness under sand for one hour. 4 grains were placed in the platina tray; and as we were so much embarrassed in the last experiment with the saline matter which adhered to the tray, we exactly balanced it with its contents. Our oxygene, made as usual, left a residuum of 2 parts in 100, and we began with 49.84 cubic inches. When every thing was adjusted, and the platina tube red hot, on passing the oxygene, flashes resembling lightning ran along the glass tube; and this was repeated 5 or 6 times. The whole of the gas became very cloudy, exhibiting a turbid milky appearance. The tube was rendered white hot by the combustion of the carbonaceous matter in oxygene. The fire was kept up about 8 minutes, and the gas passed several times. When all was cool, we could observe no alteration in the volume of gas by the register. The tray contained a mixture of salts; and being weighed, was lighter by 3.2 grains. This loss was not wholly carbon, for it is well known that animal substance contains a variety of salts, as phosphates, muriates, &c. some of which, though not volatile in a low red heat, might be decomposed and dissipated in the intense white heat produced by the combustion of the carbonaceous matter in oxygene; and we accordingly found the internal parts of the gasometers and tubes very slightly covered with a sort of efflorescence. On examining the gas after the experiment,

Lime water absorbed	41	parts from 100
The tests for oxygene	55	
Residuum	-	- 4 or an increase of 2.
		<u>100</u>

Correction for Temperature.

60°	49,84
59	,10 add for temp.
<u> </u>	<u> </u>
1 diff. or 0,103.	49,94
<u> </u>	<u> </u>

Correction for Pressure.

$$30 : 29,45 :: 49,94 : 49,02.$$

The quantity of oxygene at the mean would therefore be 49,02 cubic inches.

$$100 : 41 :: 49,02 : 20,09$$

The carbonic acid gas produced was therefore 20,09 cubic inches.

$$100 : 47,26 :: 20,09 : 9,49$$

and this carbonic acid weighed 9,49 grains.

Now the coal in the tray had lost 3,2 grains; but as the whole of this was not carbon, but part of it volatile saline matter, &c. we shall endeavour to estimate the carbon by the experiment on plumbago. When 13,35 grains of carbonic acid contained 3,80 grains of carbon,

$$13,35 : 3,80 :: 9,49 : 2,70.$$

The quantity of carbonic acid produced in this experiment, therefore, contained 2,70 grains of carbon.

Loss 3,20

Carbon 2,70

Leaves ,50 for volatile saline matter, &c.

So that this being granted, the present experiment agrees with the foregoing.

In two of our first experiments with box-wood charcoal, the calculations gave us in one case 29,75 parts of carbon in 100 of carbonic acid, and in the other 30,68; but we were not then fully aware of the absorption of water by charcoal, which rendered the quantity of real carbon employed less than indicated by the weight. Also in another experiment, in which 4 grains of diamond were consumed, the calculation gave us 29,96 per cent. of diamond in carbonic acid; but apprehending that a slight degree of inaccuracy had crept into this experiment, we have not detailed it with the rest; but we have thought it right to give a simple statement of matters of fact; in no one instance have we endeavoured to strain or accommodate these to suit any particular theory, being fully aware that every experiment, carefully made and faithfully recorded, will remain an immutable truth to the end of time, while hypotheses are constantly varying, and even the most beautiful theories are liable to change.

The experiments above related give us the following results.

	By carbonic Acid.	By Oxygene.
Box-wood charcoal	28,92	28,77
1st expt. diamond	28,95	28,81
2d expt. diamond	28,82	28,72
Stone coal -	28,20	28,27
Plumbago -	28,46	28,46
	<hr/>	<hr/>
	5)143,35	5)143,03
	<hr/>	<hr/>
mean	28,67	28,60
	<hr/>	<hr/>

Hence we conclude that 100 grains of carbonic acid contains 28,60 of carbon, which does not greatly differ from the results of the experiments of SMITHSON TENNANT, Esq. on the nature of diamond. See *Phil. Trans.* 1797.

This gentleman made his experiment in the following

manner. A quarter of an ounce of nitrate of potash was rendered somewhat alkaline by exposure to heat, in order that it might more readily absorb carbonic acid; it was then put into a gold tube with $2\frac{1}{2}$ grains of diamond, and being subjected to heat, the diamond was converted into carbonic acid, by uniting with the oxygene contained in the nitric acid. The carbonic acid thus produced combined with the potash, and on pouring a solution of muriate of lime into a solution of this salt, he obtained a precipitate of carbonate of lime: this being decomposed by muriatic acid, gave as much carbonic acid gas as occupied the space of 10,1 ounces of water. The thermometer was at 55° FAHRENHEIT, the barometer 29,80. In a second experiment he procured a larger quantity, or equal to 10,3 ounces of water.

If we therefore consider an ounce of water as consisting of 480 grains, and a cubic inch of water equal to 253 grains, and then make the proper corrections for temperature and pressure, one of his experiments will give about 27 per cent. the other about 27,80 for the carbon in carbonic acid, which is somewhat less than our estimate; but the difference may easily be accounted for, from the different methods employed.

The experiments of GUYTON, as detailed in the *Annales de Chimie*, vol. XXXI, page 76, are liable to very strong objections; but at the same time the candid manner in which he has related every circumstance merits considerable praise. It is impossible, however, not to observe, that the quantity of gas before and after the experiment could not, from the construction of his apparatus, be very rigorously ascertained. We object also to nitrous gas as a test for oxygene; and as it is acknowledged that the wooden support included in the oxygene gas took fire, the product of carbonic acid must have

been influenced by it; so that if no chance of error had existed in estimating the carbonic acid gas from the residuum after barytic water had absorbed a part, still the result would not have been satisfactory.

The experiments which we have had the honour of laying before this Society prove several important points:

1st. That the estimate given by LAVOISIER, of 28 parts of carbon in every 100 parts of carbonic acid, is very nearly correct; the mean of our experiments makes it 28,60.

2dly. That the diamond is pure carbon; for had it contained any notable proportion of hydrogene, it must have been discovered, either by detonating with the oxygene, as in the case of animal charcoal, or by diminishing the quantity of oxygene gas.

3dly. That well burnt charcoal contains no sensible quantity of hydrogene; but if exposed to the air for a few hours it absorbs moisture, which renders the results uncertain.

4thly. That charcoal can no longer be considered as an oxide of carbon, because, *when properly prepared*, it requires quite as much oxygene for its combustion as the diamond. This is also the case with stone coal and plumbago.

5thly. It appears that diamond and all carbonaceous substances (as far as our present methods of analysis are capable of demonstrating their nature) differ principally from each other in the state of aggregation of their particles. BERTHOLLET has well remarked, that in proportion as this is stronger, decomposition is more difficult: and hence the variety of temperatures required for the combustion of different inflammable substances.

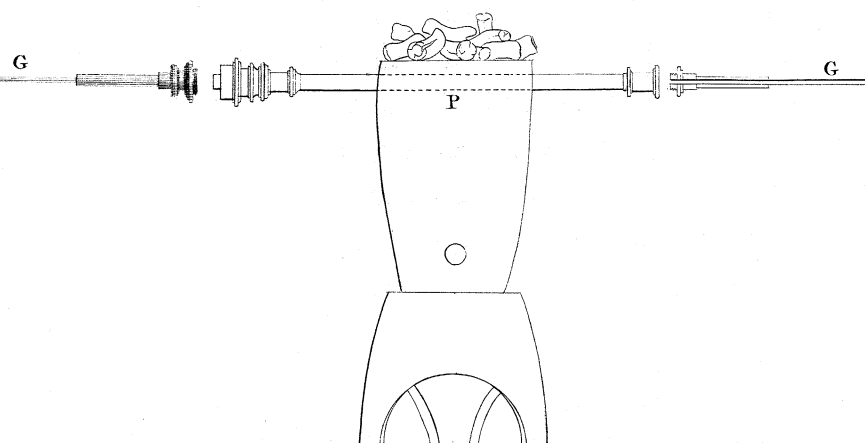
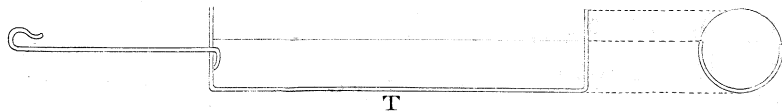
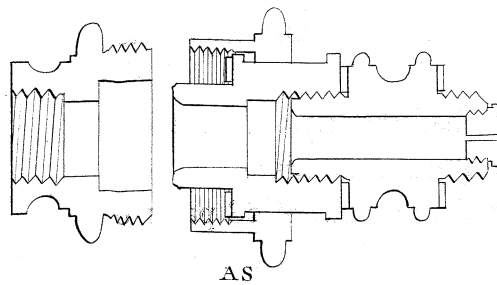
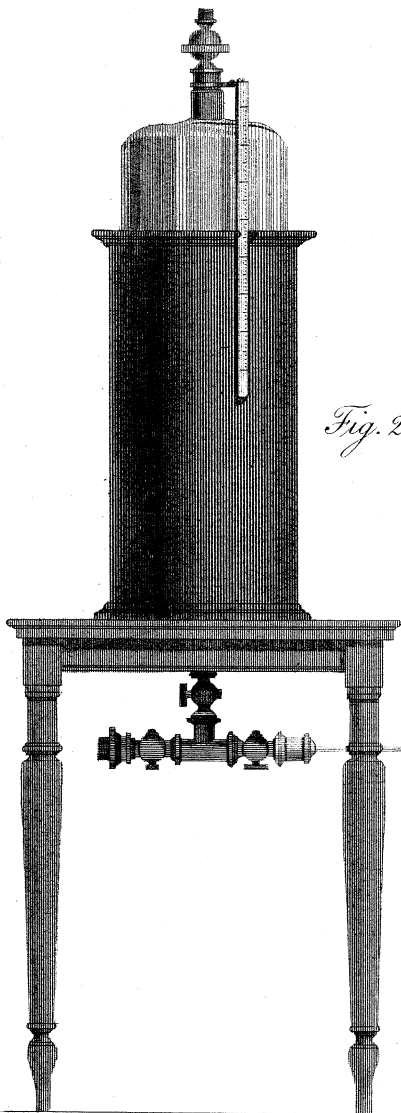

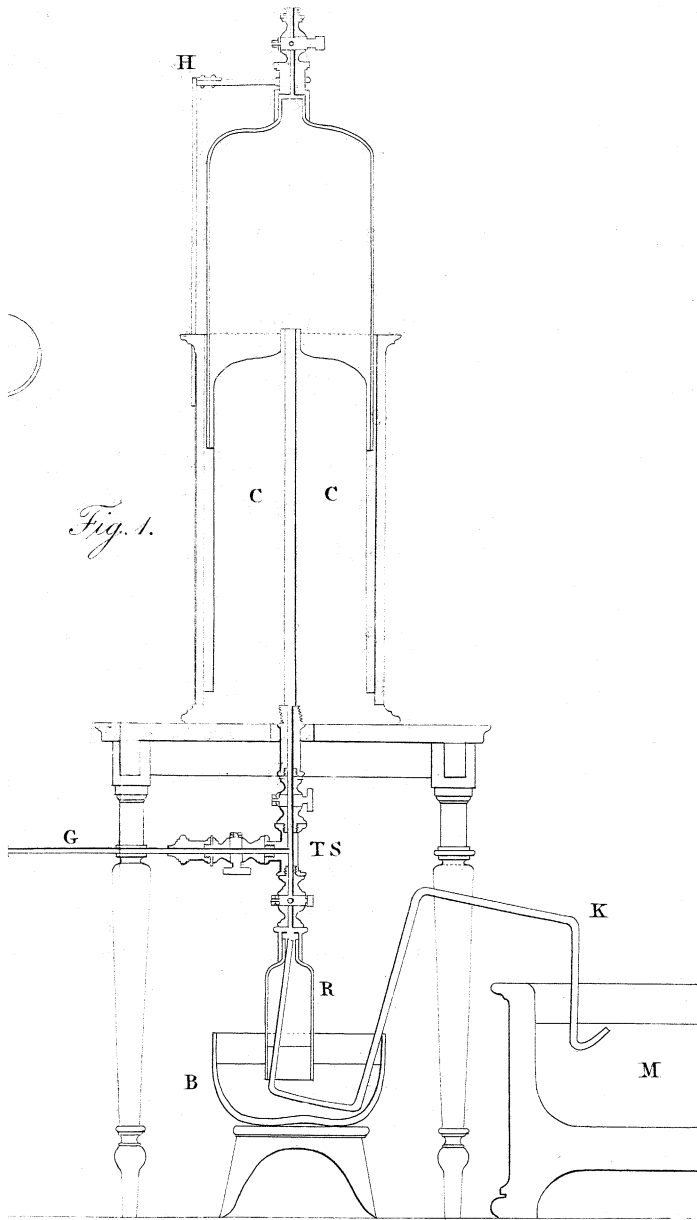

Fig. 1.

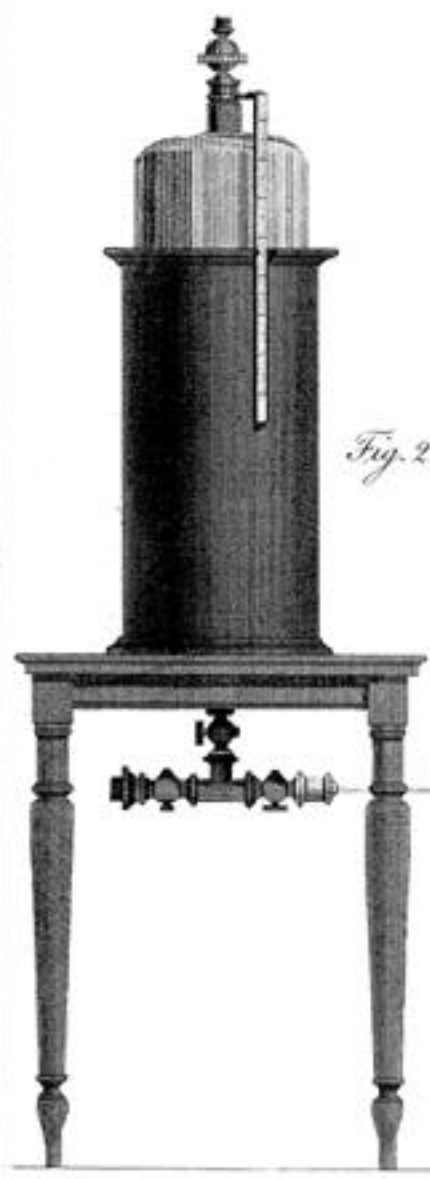
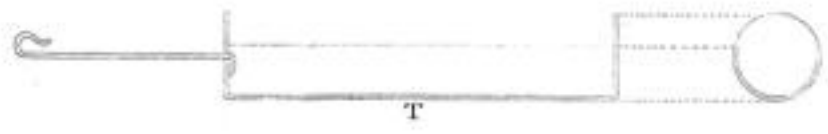
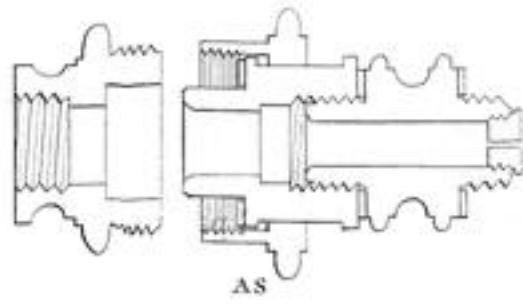

Fig. 2.

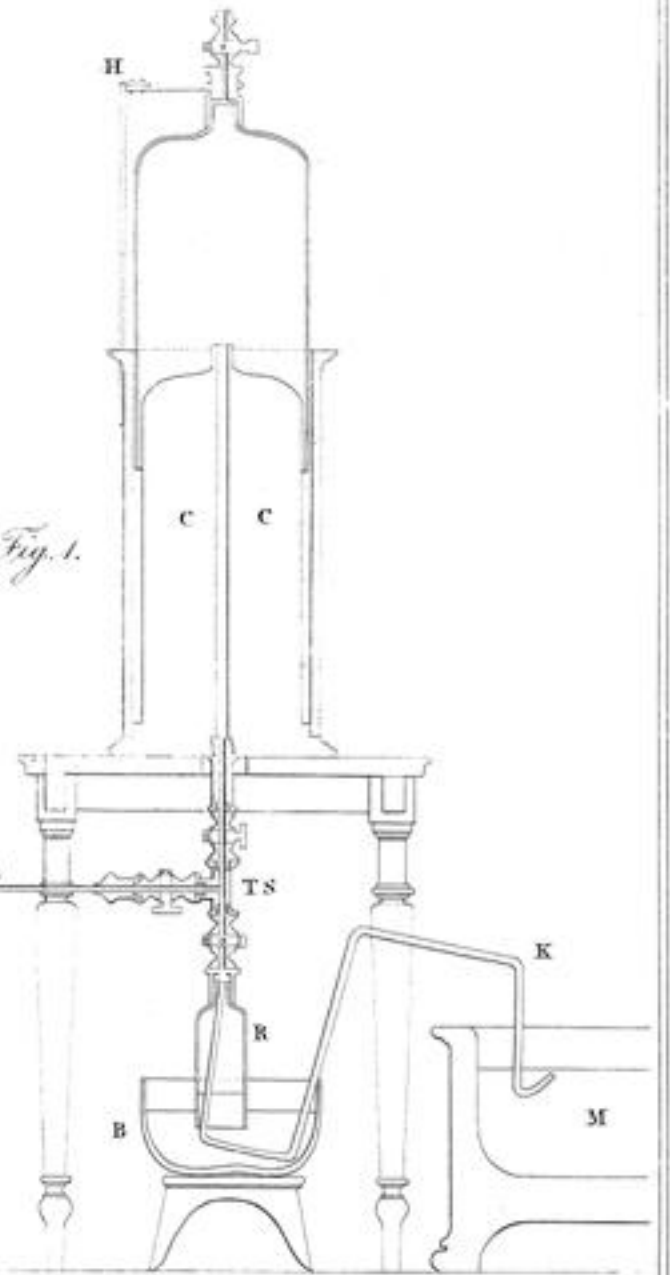

Fig. 1.